

TNB-4M FLANGE BRACKET

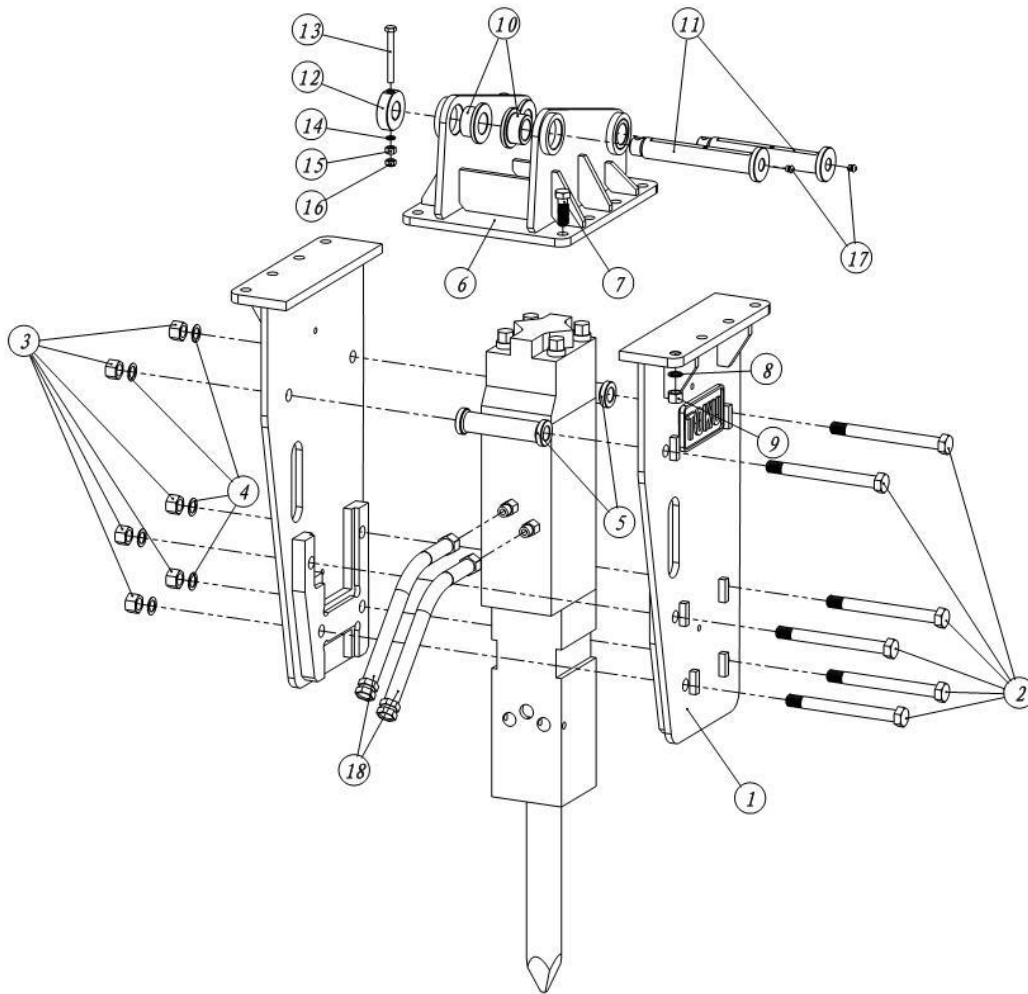

NO.	DESCRIPTION	PART CODE.	QUANTITY
1	FLANGE BRACKET	BKT-4M-FL	1 SET
2	BRACKET BOLT [M24*240]	BLT-M24-240	6
3	BRACKET BOLT NUT [M24]	NUT-M24	6
4	BRACKET BOLT WASHER [M24]	WASHER-M24	6
5	SPACER	SPACER-28-180	2
6	TOP CAP	Per Machine Model	1
7	H.T BOLT [M16*55]	BLT-M16-55	10
8	WASHER [M16]	WASHER-M16	10
9	H.T NUT [M16]	NUT-M16	10
10	TOP CAP BUSHING	N/A	4
11	TOP CAP PIN	N/A	2
12	TOP CAP RING	N/A	2
13	H.T BOLT [M10*90]	Upon Request	2
14	WASHER [M10]	Upon Request	2
15	H.T NUT [M10]	Upon Request	2
16	U NUT [M10]	Upon Request	2
17	GREASE NIPPLE	N/A	2
18	MX MALE HOSE	SGH-2081	1
	MX FEMALE HOSE	SGH-2091	1
	SSL MALE HOSE	SGH-2079	1
	SSL FEMALE HOSE	SGH-2090	1