

**TNB-230LU1 KEY TYPE BOX BRACKET CP**

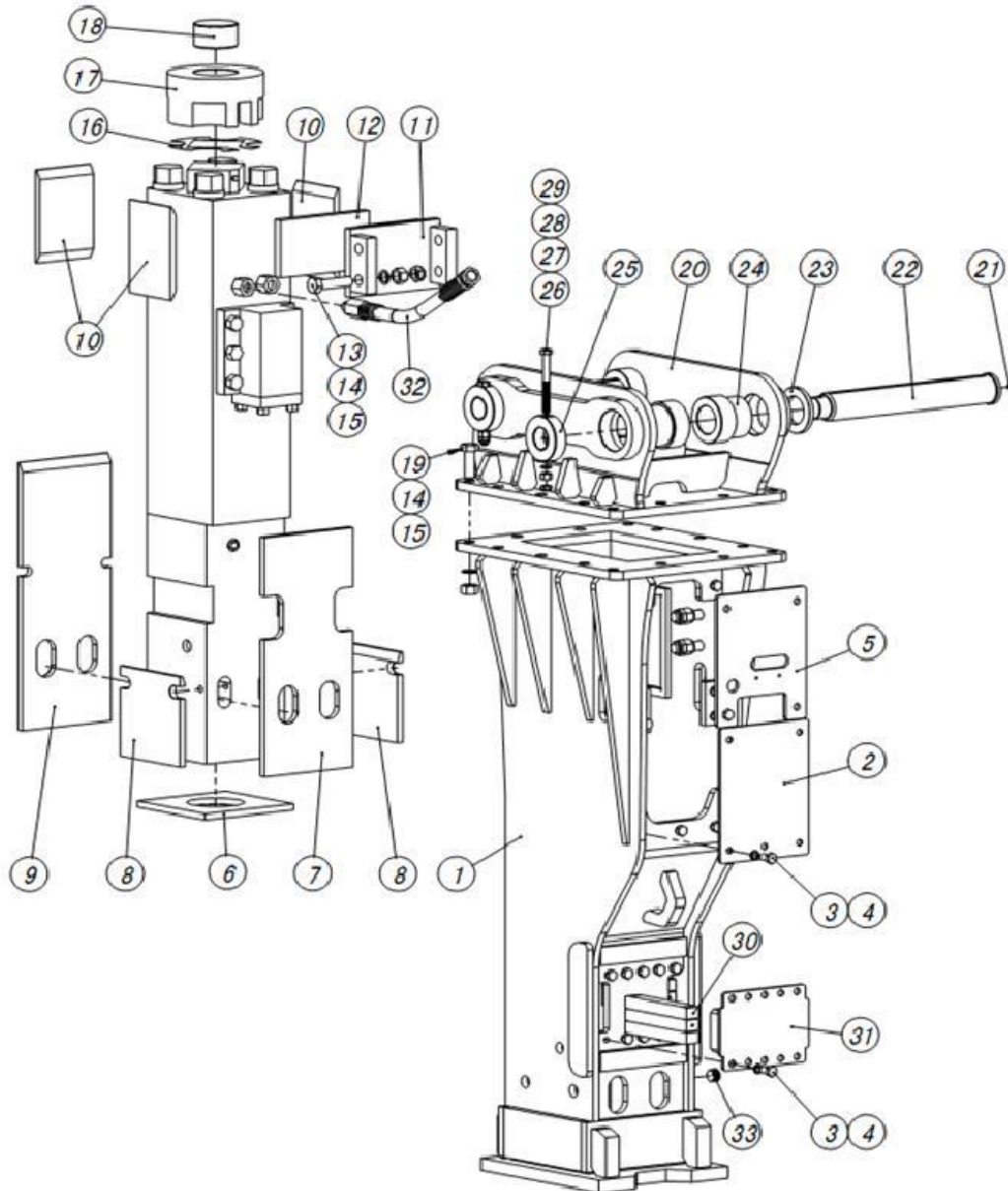

NO.	DESCRIPTION	PART CODE.	QUANTITY
1	KEY TYPE BOX BRACKET	BKT-230LU1	1
2	CONTROL VALVE PLATE	230002	1
3	H.T BOLT [M20*30]	BLT-M20-30	19
4	SPRING WASHER [M20]	WASHER-M20	19
5	GAS VALVE COVER PLATE	230005-2	1
6	UNDER SPACER	230006	1
7	CHISEL HOLDER SPACER	230007-2	1
8	SIDE SPACER	230008	2
9	BACK SPACER	230009	1
10	SMALL SPACER	230010	3
11	GUIDE PLATE	230011	1
12	GUIDE SPACER	230012	1
13	H.T BOLT [M30x120]	BLT-M30-120	4
14	SPRING WASHER [M30]	WASHER-M30	18
15	H.T NUT [M30]	NUT-M30	20
16	ADJUST MAT	230016	1
17	ISOLATOR TOP COVER	230017	1
18	NYLON POLE	230018	1
19	H.T BOLT [M30x90]	BLT-M30-90	14
20	TOP CAP	PER MACHINE MODEL	1
21	GREASE NIPPLE	N/A	2
22	BRACKET PIN	PER MACHINE MODEL	2
23	BRACKET PIN STOPPER	UPON REQUEST	2
24	BRACKET BUSH	PER MACHINE MODEL	4
25	BRACKET RING	UPON REQUEST	2
26	H.T BOLT [M20x200]	UPON REQUEST	2
27	SPRING WASHER [M20]	UPON REQUEST	2
28	H.T NUT [M20]	UPON REQUEST	2
29	U NUT [M20]	UPON REQUEST	2
30	ASSEMBLED LOCALIZER	230030	2 SETS
31	COVER PLATE	230032-2	1
32	HOSE	SGH-2109 or SGH-2111	2
33	PLUG ZG1 1/4"	136096128	1