

# TNB-400LU BOX BRACKET

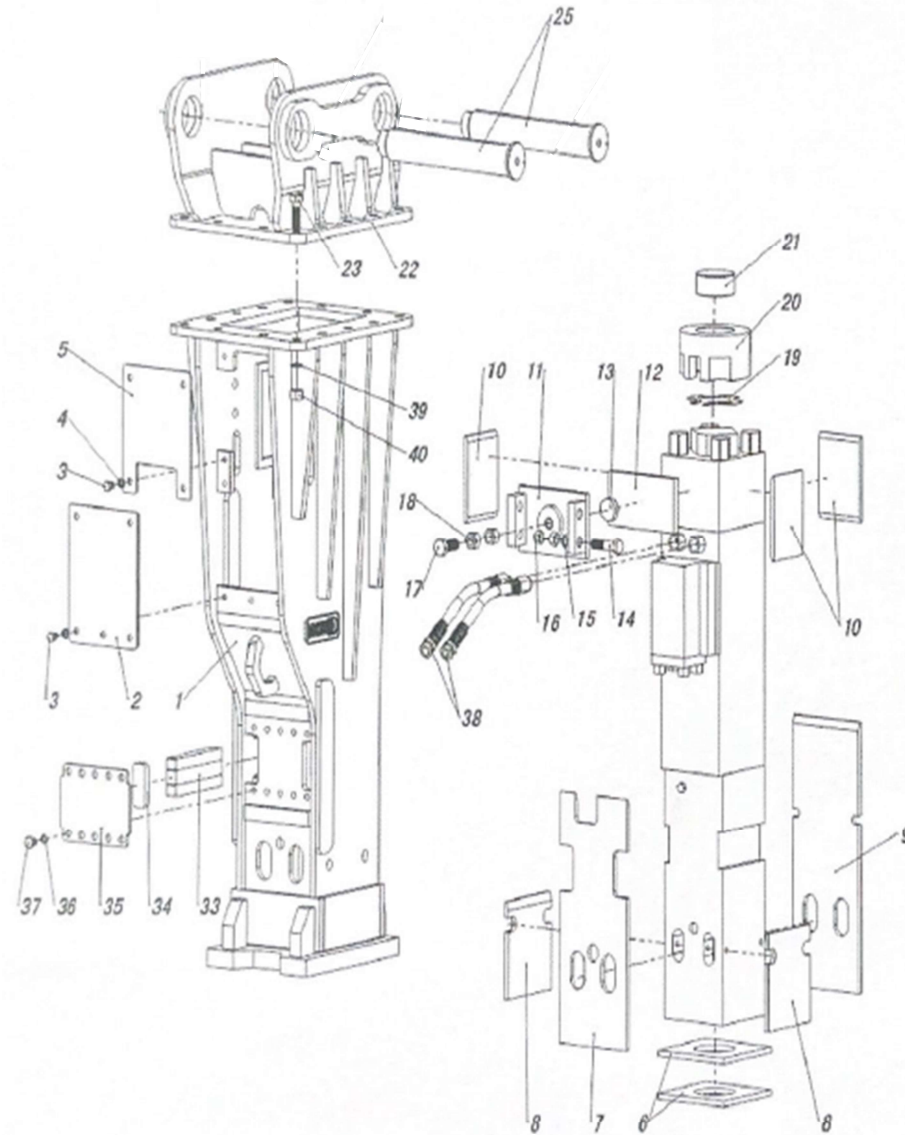

## Parts

Sym	Part Code	Description	Q'ty	Int	Kit
1	BKT-400-ST-W / O TC	Box Bracket CP	1		
2	400002	Control Valve Plate	1		B
3	BLT-M20-35	H.T Bolt M20x35	9		B
4	WASHER-M20	Washer 20	9		B
5	400005	Gas Valve Cover Plate	1		B
6	400006	Under Spacer	2		B
7	400007	Chisel Holder Spacer	1		B
8	400008	Side Spacer	2		B
9	400009	Back Spacer	1		B
10	400010	Small Spacer	3		B
11	400011	Guide Plate	1		B
12	400012	Guide Spacer	1		B
13	400013	Small Nylon Pole	1		B
14	BLT-M30-130	H.T Bolt M30x130	4		B
15	WASHER-M30	Washer 30	4		B
16	NUT-M30	H.T Nut M30	8		B
17	BLT-M39-105	H.T Bolt M39x105	1		B
18	NUT-M39	H.T Nut M39	16		B
19	400016	Adjust Mat	1		B
20	400017	Top Cover	1		B
21	400018	Nylon Pole	1		B
22	PER MACH. MODEL	Top Cap	1		
23	BLT-M39-105	H.T Bolt M39x105	14		B
25	PER MACH. MODEL	Bracket Pin Kit	1		T
33	400030	Assembled Localizer	2		B
34	400031	Rubber Plate			B
35	400032	Cover Plate	1		B
36	WASHER-M24	Washer 24	10		B
37	BLT-M24-35	H.T Bolt M24x35	10		B
38	136096128	Plug ZG1 1/4"	1		B
39	SGH-2121-MS	Hose	2		
40	WASHER-M39	Washer 39	14		B

Box Bracket CP consists of parts marked "B"

Top Cap consists of parts marked "T"

For Decal and/or Tool Box information, please contact your Dealer

INT(interchangeability)

- Interchangeable old ↔ new
- △ Interchangeable old → new
- ▲ Interchangeable old ← new
- × Not interchangeable