

TNB-6M-BX

5/1/2023

No.1

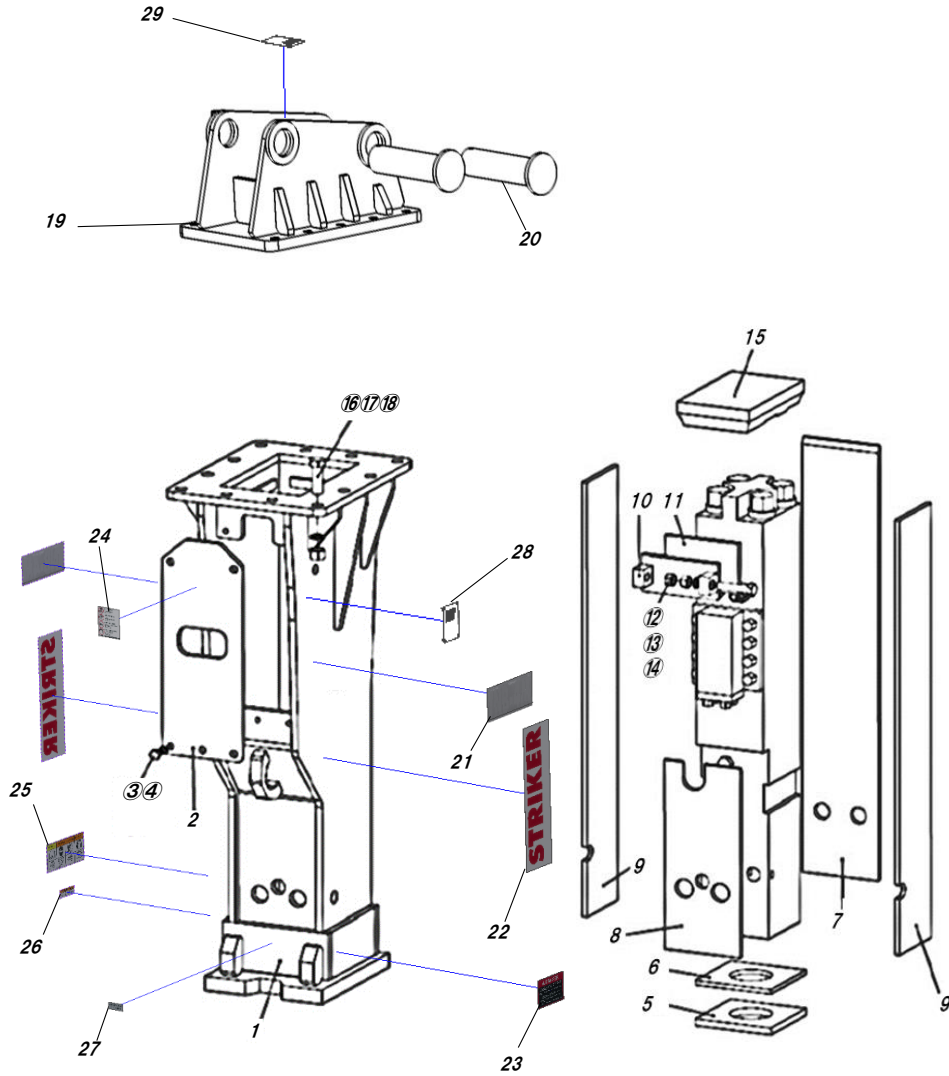

Item No.	Item Code	Item Description	Q'ty
1	BKT-6M-BX	Box Bracket	1 Set
2	6M002	Control valve plate	1
3	BLT-M12-25	Hex Bolt M12 x 25	5
4	WASHER-M12	Washer	5
5	6M005	Under Spacer A	1
6	6M006	Under Spacer B	1
7	6M007	Back spacer	1
8	6M008	Chisel Holder spacer	1
9	6M009	Side Spacer (L,R)	2
10	6M010	Guide Plate	1
11	6M011	Guide Spacer	1
12	BLT-M16-75	Hex Bolt M16 x 75	2
13	WASHER-M16	Washer M16	2
14	NUT-M16	H.T.NUT M16	4
15	6M015	Top Cover Isolator	1
16	BLT-M20-60	Hex Bolt M20 x 60	12
17	WASHER-M20	Washer M20	12
18	NUT-M20	HT Nut M20	12
19	Per Machine Model	Top bracket	1
20	Per Machine Model	Top Cap Pin	2
21	DECAL-6M	TNB-6M	2
22	STRIKER-LARGE	Striker Decal (Large)	2
23	DANGER-RED	Caution 1	1
24	CAUTION - WHITE	Caution 2	1
25	WARNING- LARGE	Caution 4	1
26	PRO65-DECAL	California Decal	1
27	GREASE-DECAL	Grease Daily	1
28	BR-Name Plate	Breaker Name Plate	1
29	TB-Name Plate	Top Bracket Name Plate	1

※For Tools, Hydraulic Hoses and Tool Box please contact Your Dealer.