

# TNB-6M-FL-JD

5/1/2023  
No.1

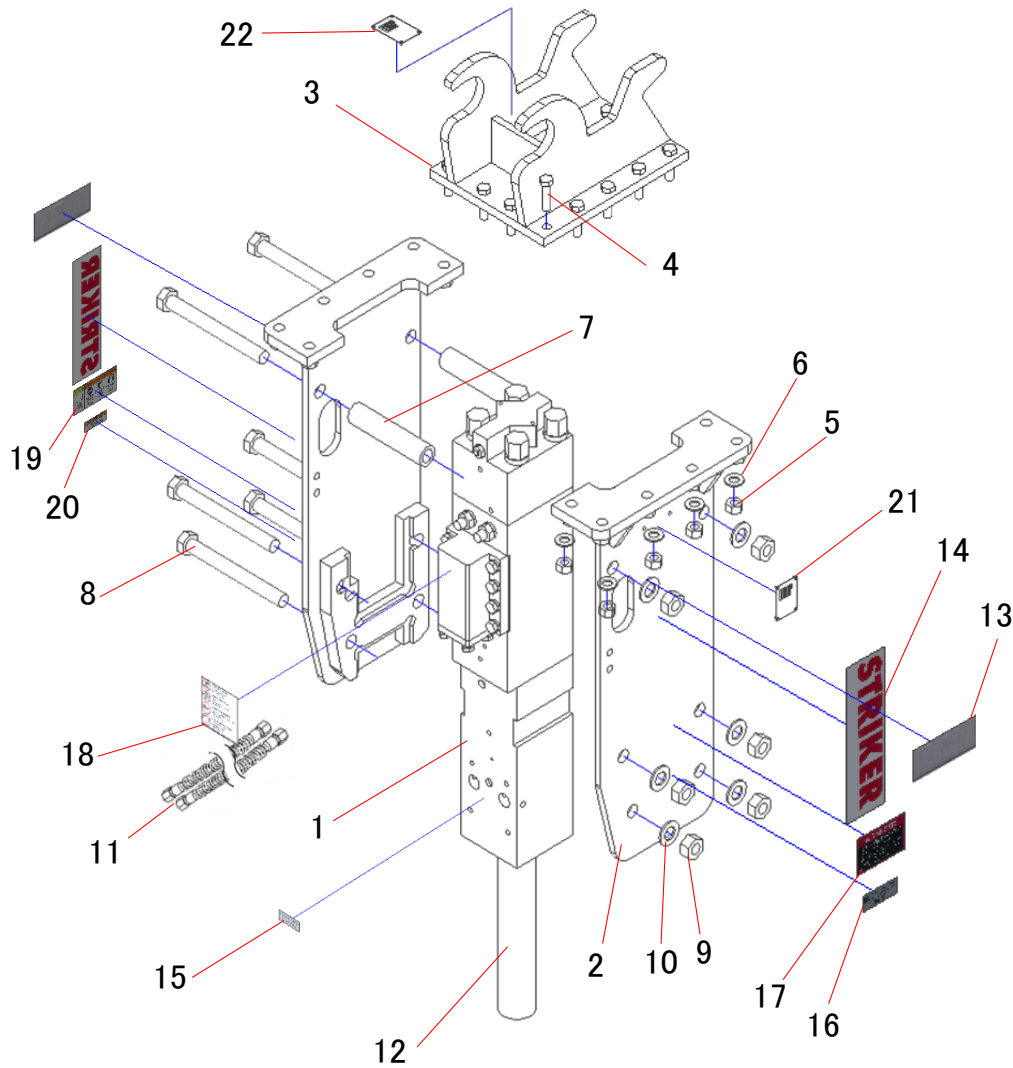

Item No.	Comp Item Code	Comp Item Description	Q'ty
1	515175	Bare Breaker, 6M	1
2	BKT-6M-FL-BD	Flange Plates, B&D, 6M	1
3	Per Machine Model	DEERE ZTS	1
4	BLT-M20-60	BOLT H.T CL. 10 M20x60	14
5	NUT-M20	Nut, H.T., M20	14
6	WASHER-M20	Washer, Ribbed, M20	14
7	SPACER-24-200	SPACER 24X200 (TNB-5M SSL, MX	2
8	BLT-M27-265	Bolt, M27x265, GR8	6
9	NUT-M27-LN	NUT M27 Nylon Lock Class 10 Zi	6
10	WASHER-M27	Washer	6
11	SGH-2079	Hydraulic Hose Nipple	1
	SGH-2090	Hydraulic Hose Coupler	1
12	415118412	Moil Point	1
13	DECAL-6M	TNB-6M	2
14	STRIKER-LARGE	Striker Decal (Large)	2
15	GREASE-DECAL	Grease Daily	1
16	BOLT - DECAL	Check Loose bolts	1
17	DANGER-RED	Caution 1	1
18	CAUTION - WHITE	Caution 2	1
19	WARNING- LARGE	Caution 4	1
20	PRO65-DECAL	California Decal	1
21	BR-Name Plate	Breaker Name Plate	1
22	TB-Name Plate	Top Bracket Name Plate	1

※For other tools and Tool Box please contact Your Dealer.