

# TNB-6M-FL

5/1/2023  
No.1

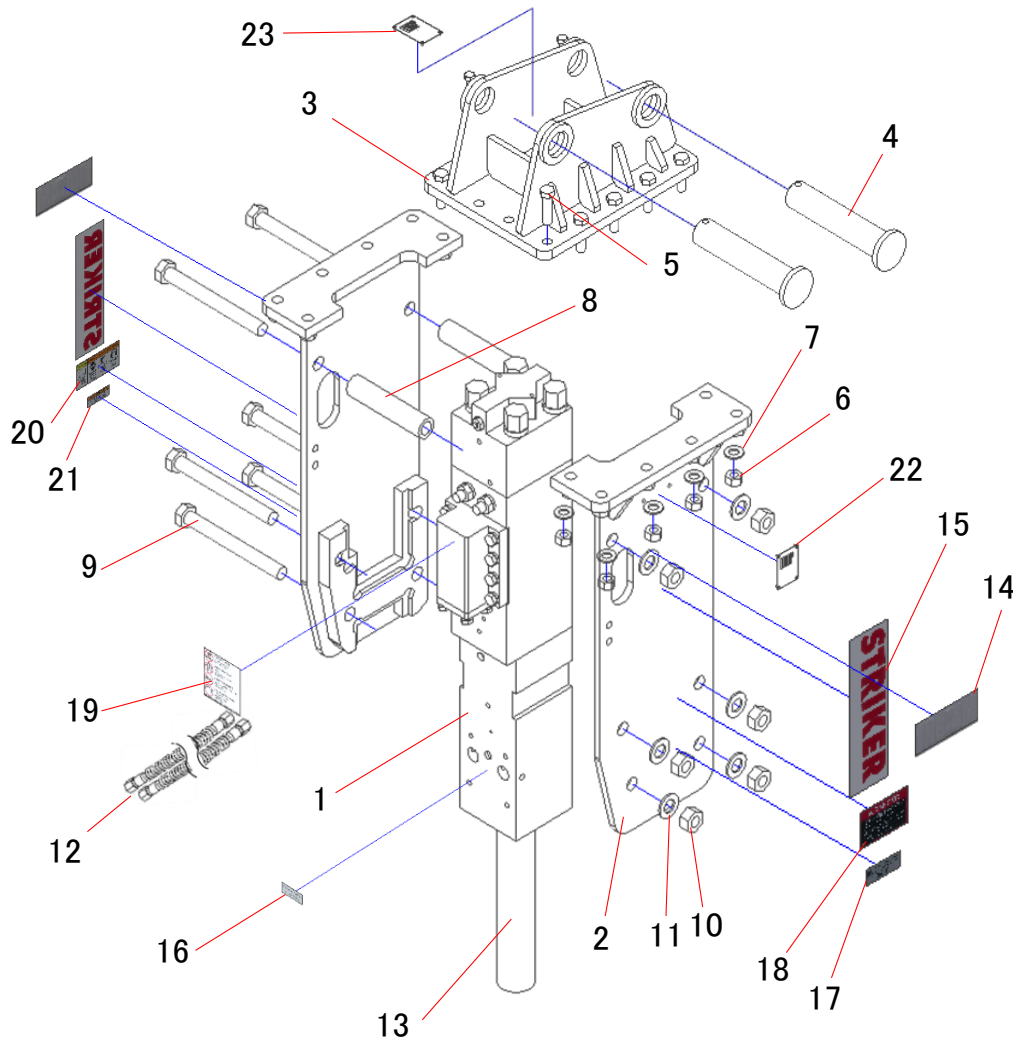

Item No.	Item Code	Item Description	Q'ty
1	515175	Bare Breaker, 6M	1
2	BKT-6M-FL-BD	Flange Plates, B&D, 6M	1
3	Per Machine Model	Top Bracket	1
4	Per Machine Model	Top Cap Pin	2
5	BLT-M20-60	BOLT H.T CL. 10 M20x60	14
6	NUT-M20	Nut, H.T., M20	14
7	WASHER-M20	Washer, Ribbed, M20	14
8	SPACER-24-200	SPACER 24X200 (TNB-5M SSL, MX	2
9	BLT-M27-265	Bolt, M27x265, GR8	6
10	NUT-M27-LN	NUT M27 Nylon Lock Class 10 Zi	6
11	WASHER-M27	Washer	6
12	SGH-2079	Hydraulic Hose Nipple	1
	SGH-2090	Hydraulic Hose Coupler	1
13	415118412	Moil	1
14	DECAL-6M	TNB-6M	2
15	STRIKER-LARGE	Striker Decal (Large)	2
16	GREASE-DECAL	Grease Daily	1
17	BOLT - DECAL	Check Loose bolts	1
18	DANGER-RED	Caution 1	1
19	CAUTION - WHITE	Caution 2	1
20	WARNING- LARGE	Caution 4	1
21	PRO65-DECAL	California Decal	1
22	BR-Name Plate	Breaker Name Plate	1
23	TB-Name Plate	Top Bracket Name Plate	1

※1・・・For Hydraulic Hose and/or Moil Point please contact Your Dealer.

※For Decal and/or Tool Box please contact Your Dealer.