

# TNB-151LU1-K BOX BRACKET

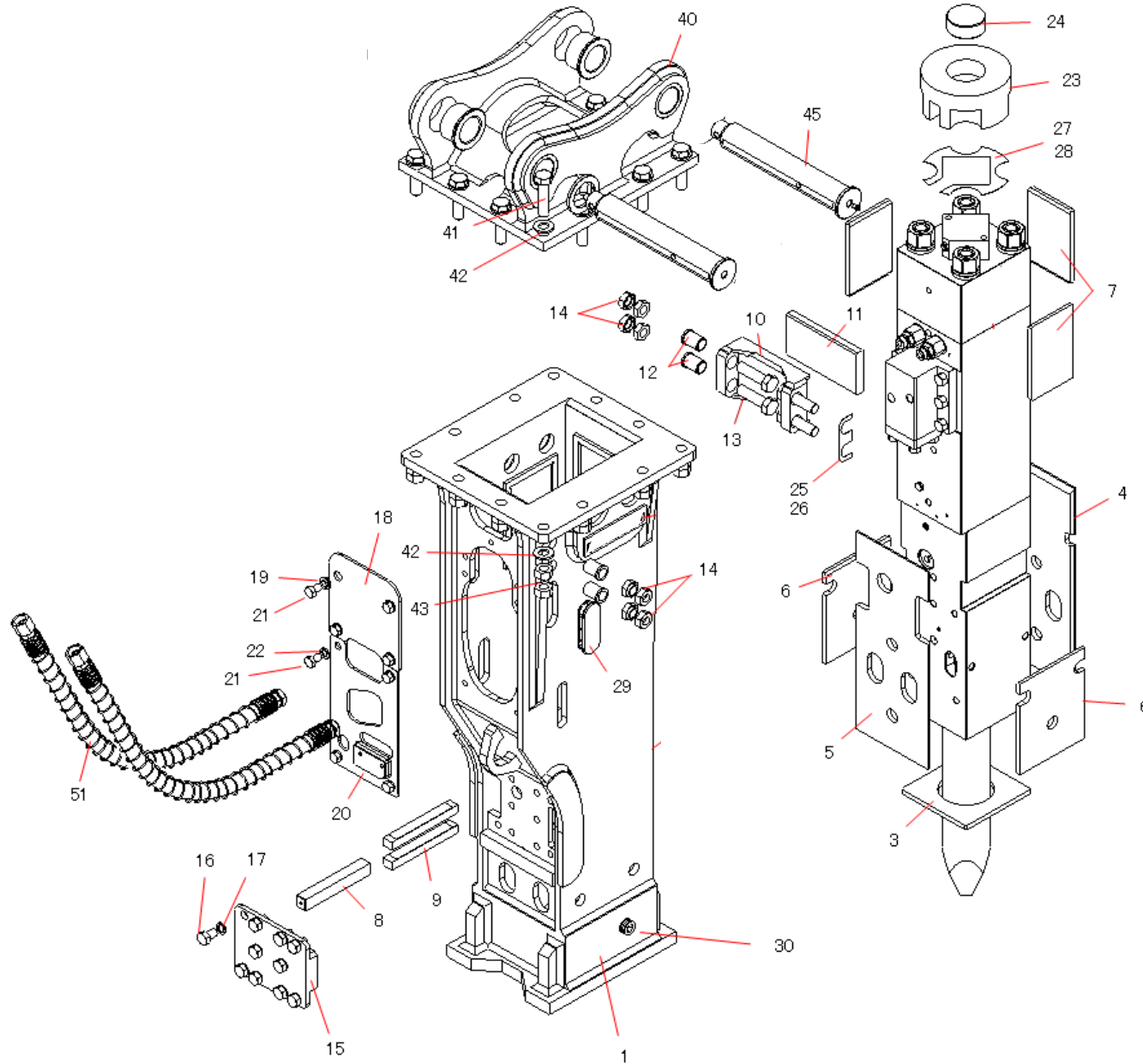

## Parts

2018.08.27

No.1

Sym	Part Code	Description	Q'ty	Int	Kit
1	BKT-151LU1-K	BOX BRACKET CP	1		
3	151006-K	UNDER SPACER	1		B
4	151009-K	BACK SPACER	1		B
5	151007-K	CHISEL HOLDER SPACER	1		B
6	151008-K	SIDE SPACER	2		B
7	151010	SMALL SPACER	3		B
8	151030-K	ASSEMBLED LOCALIZER	2		B
9					
10	151011-K	GUIDE PLATE	1		B
11	151012-K	GUIDE SPACER	1		B
12	151013-K	GUIDE BUSH	4		B
13	BLT-M30-110	BOLT M30X110	4		B
14	NUT-M30	NUT M30	4		B
15	151032-K	COVER PLATE	1		B
16	BLT-M24-35	BOLT M24X35	10		B
17	WASHER-M24	WASHER M24	10		B
18	151005-K	GAS VALVE COVER PLATE	1		B
19	151019-K	SLEEVE WASHER	4		B
20	151002-K	CONTROL VALVE PLATE	1		B
21	BLT-M20-35	BOLT M20X35	8		B
22	WASHER-M20	WASHER M20	4		B
23	151017	ISOLATOR TOP COVER	1		B
24	151018	NYLON POLE	1		B
25	151025-K	GUIDE PLATE SHIM 0.5	1		
26	151026-K	GUIDE PLATE SHIM 1.0	1		B
27	151016	ADJUST MAT 1.0	1		
28	151016-2	ADJUST MAT 2.0	1		B
29	151029	SIDE PLUG	2		B
30	136096128	PLUG ZG1 1/4"	1		B
40	PER MACHINE MODEL	TOP CAP	1		
41	BLT-M30-120	BOLT	12		B
42	WASHER-M30	WASHER	24		B
43	NUT-M30	NUT	24		B
45	PER MACHINE MODEL	BRACKET PIN KIT	1		T
51	SGH-2109	HOSE	2		

Box Bracket CP consists of parts marked "B"

Top Cap consists of parts marked "T"

For Decal and/or Tool Box information, please contact your Dealer

INT(interchangeability)

○ Interchangeable old ↔ new

△ Interchangeable old → new

▲ Interchangeable old ← new

× Not interchangeable