

TNB-2M MX

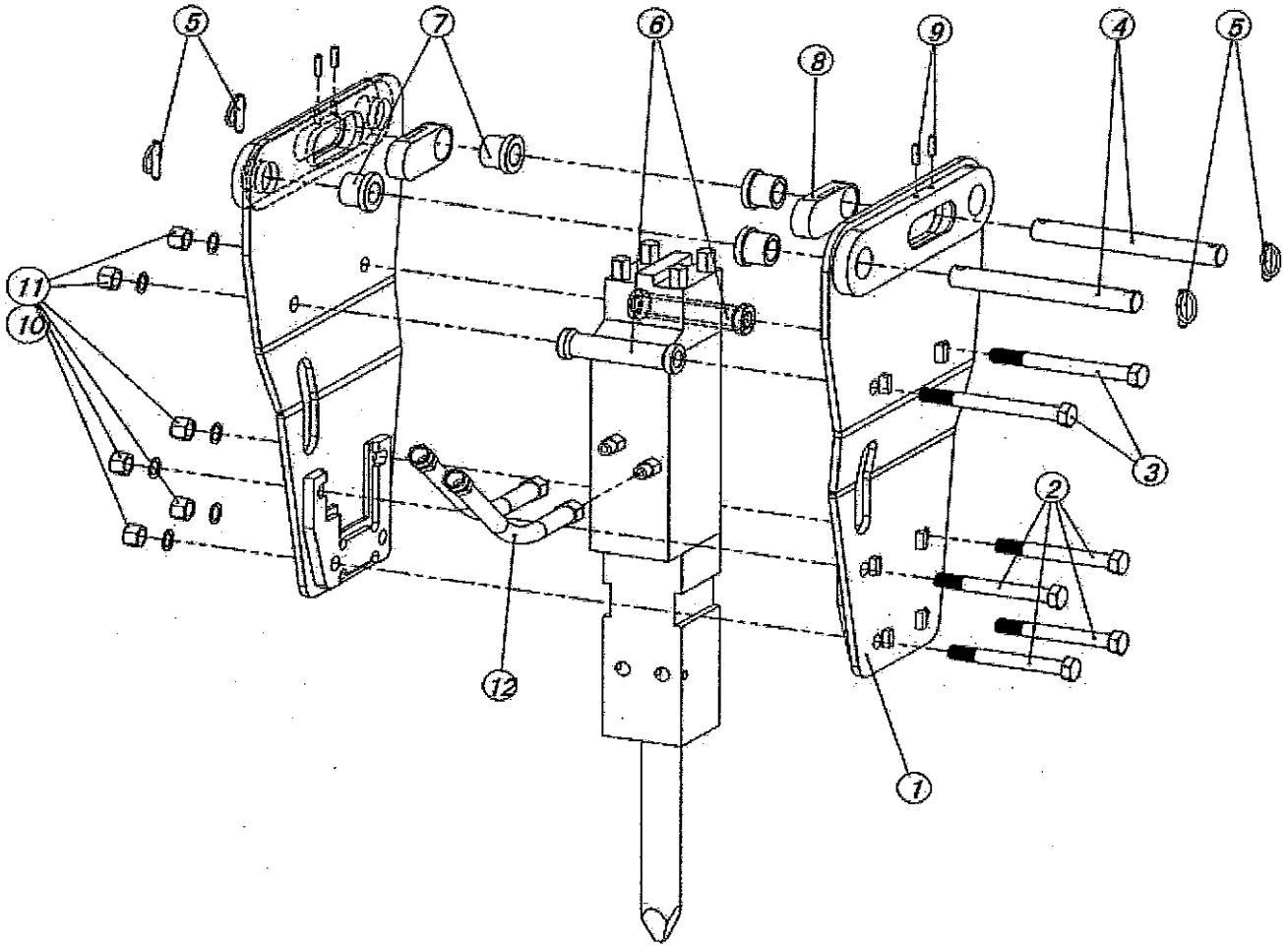

Item	Description	Part Number	Q'ty
1	Side Plates	BKT-2M-BD	1 set
2	Bracket Bolts(S)	BLT-M22-180	4
3	Bracket Bolts(L)	BLT-M22-240	2
4	Pins	Per Machine Model	2
5	Lynch Pin	PIN-CLIP	4
6	Spacer	SPACER-44.5-190	2
7	Bushings	Per Machine Model	4
8	Oval Insert	Per Machine Model	2
10	Washer	WASHER-M22	6
11	Nut	NUT-M22	6
12	Hose Coupler	SGH-2095	1
	Hose Nipple	SGH-2094	1
	Moil Point	415108410	1

For Decal and/or Tool Box please contact Your Dealer